



FORUM

MINI FORECAST ALUMINUM SERIES

4"x3" DIRECT PENDANT / SURFACE / WALL MOUNT

JOB _____

FIXTURE TYPE _____

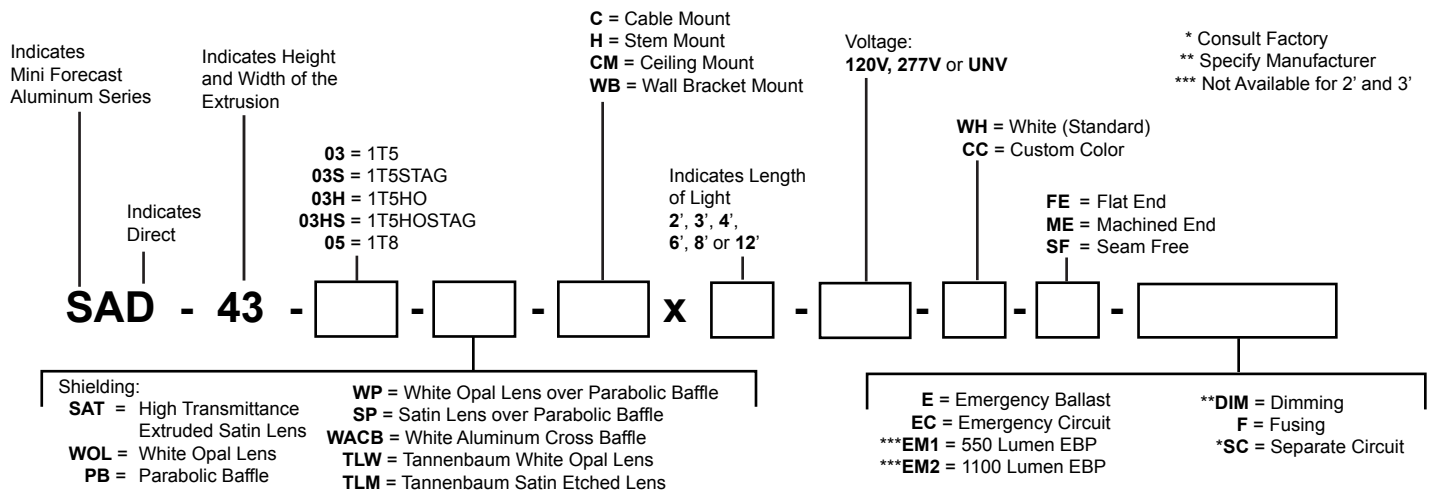
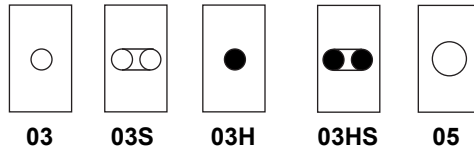
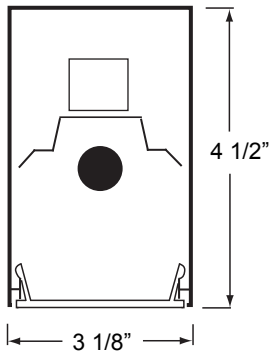

MOUNTING OPTIONS

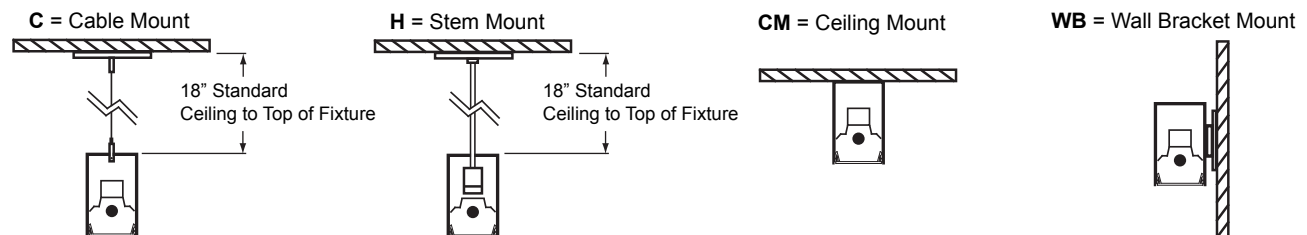

DESCRIPTION

The **MINI-FORECAST** series is a compilation of rectilinear profiles specifically designed for the specification market. Clean aesthetic lines are achieved through the use of extruded external housing components, produced from aircraft grade aluminum that provides a structurally integral unitized assembly. Attention to function is evident in the design of the internal joining components which are die formed and designed to ease the process for the installing contractor. Superior optical performance is achieved through the use of computer enhanced reflector design and cutting edge coating materials. The Mini-Forecast family of products brings classic style forward to a new level of performance.

SPECIFICATION

HOUSING: Comprised of multiple extruded profiles to provide a nominal 4x3 housing envelope. 6063-T5 alloy is used to achieve a minimum wall thickness of 0.070". All housings are finished through a multistage triphosphor wash cycle followed by the electrostatic application of a polyester hybrid powder coat which is then baked on to achieve a uniform white finish. Custom colors are available to the designer.

END FITTINGS: Applied end fitting options give the designer vast flexibility in the final appearance of the luminous system. Standard, a flat end of .090" thick aluminum minimum is applied with concealed fasteners, providing a hairline seam that compliments the clean lines of the rectilinear shape.

REFLECTOR: Computer enhanced design is applied to a 22 gauge aluminum sub straight. The reflector is coated with an optically pure white finish that provides a minimum reflectance of 86%.

BALLAST: Each luminaire is provided with an electronic ballast. Standard, a multi-lamp high power factor, low THD universal voltage product is used. If a project requires a specific performance ballast please contact the factory for availability.

SHIELDING: A virgin acrylic high transmittance extruded snap in satin lens is provided as standard. Numerous options are available to the lighting designer to shape the feel of the architectural space.

WOL: White opal lens, a 1/8" thick white translucent lens is provided that "lifts & shifts" into, and out of the luminaire.

PB: Parabolic louver, a low iridescent semi-specular aluminum parabolic cross blade louver. The parabolic louver is secured into the housing with spring steel clips that engage the extruded aluminum housing. The parabolic cross blade are 3/4" high and set 2" on center.

WACB: Flat cross blade louver, white aluminum flat cross blade louver. The white cross blade louver is provided that "lifts & shifts" into, and out of the luminaire. The louver is constructed with a cold weld process that yields a blade height of 1/2" set at 1/2" on center.

TLX: Tannenbaum profile side insert, an extruded insert that regresses the diffusing media into the fixture aperture 1". The application of the Tannenbaum profile adds visual interest while maintaining the performance of the fixture.

CABLE SUPPORT: 1/16" thin stainless steel aircraft cable, pre-installed at the factory to help reduce labor and confusion in the field. Provided as standard, a fully adjustable 18" hanging assembly is supplied. Varying lengths are available upon request. At all power feed locations an 18/3 white SJT power cord is provided and installed as well.

LISTINGS: All fixtures bare an AFL-CIO/IBEW union label and are UL listed for damp location.