



FORUM

MINI FORECAST SERIES

INDIRECT

4"x4" PENDANT / WALL MOUNT

JOB _____

FIXTURE TYPE _____

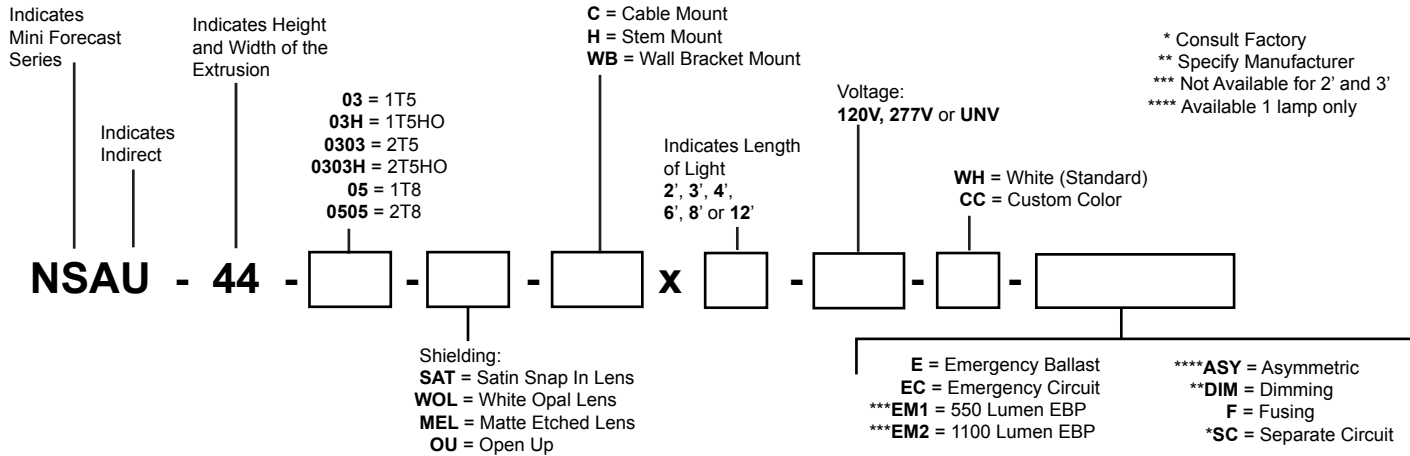
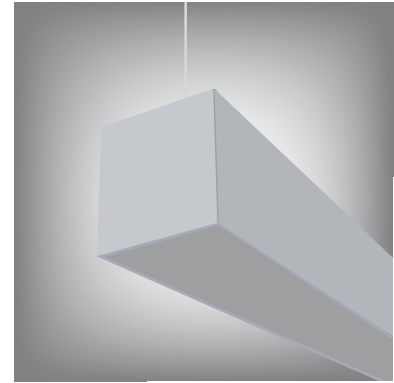
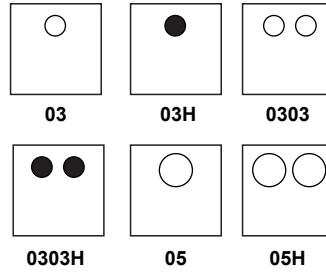
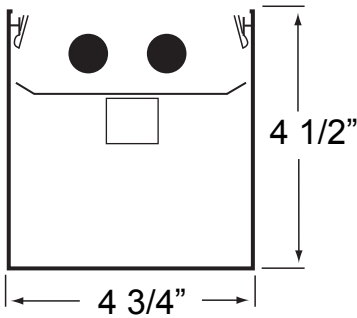

MOUNTING OPTIONS

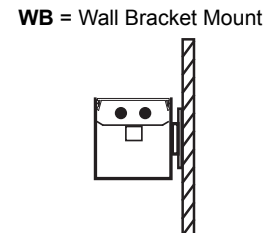
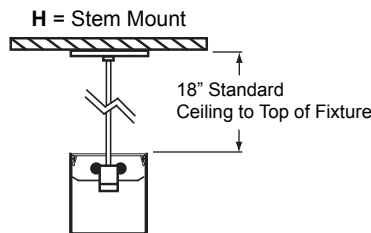
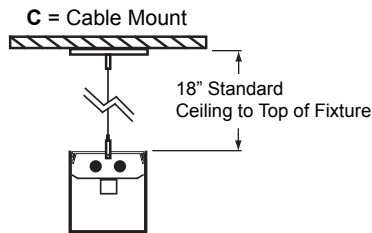

SPECIFICATION

The **FORUM/MINI FORECAST** housing shall be a nominal 4 inches high by 4 inches wide with the sides and bottom consisting of aluminum extrusion 6063-T5 alloy (.070" minimum wall thickness). Sockets shall be prewired and factory installed. The ends shall be .090 inch thick aluminum with no visible fasteners. Standard continuous single sections shall be up to 12 feet.

Standard finish shall be white polyester powder coating pretreated with a five (5) stage cleaning/conversion coating rust inhibitor. Other architectural finishes available as well as satin anodized.

REFLECTOR: Shall be die formed 22 gauge aluminum with 86% reflectivity.

BALLAST: Electronic high power factor with <10% THD with disconnect.

CABLE SUPPORT: Factory installed hanger system is adjustable at the fixture with a 1/16" diameter cable. A factory installed straight power cord (standard) is attached to the fixture.

STEM: 5/8" diameter with a 1 5/8" deep canopy allowing for a 45 degree swivel when specified. Canopy and stem shall be painted white.

PRODUCT LISTING: Shall be U.L. listed for damp locations.