



FORUM

QUASAR/PROJECTOR WALL MOUNT

JOB _____

TYPE _____

FORUM QUASAR/PROJECTOR SERIES

The **QUASAR/PROJECTOR** is a heavy duty, remote ballasted floodlight with a high degree of beam control. The optics are designed to evenly illuminate either vertical or horizontal surfaces.

APPLICATIONS: Classrooms, Office Areas, Libraries, Lobbies, Retail Stores.

MOUNTING: The **QUASAR/PROJECTOR** can be floor, parapet, ceiling, or wall mounted.

SPECIFICATION:

HOUSING: Shall be .125" thick extruded 6063 -T5 aluminum with external surface ribbing for improved heat dissipation which will prolong lamp life. The standard finish for the housing is white. The end plates shall be .375" thick aluminum, gasketed and mechanically attached to the housing. The ends shall be painted white (standard). Custom finishes and bright dip anodize finish available. Consult factory.

LENS AND FRAME: Shall be .125" thick high temperature clear patterned tempered glass. The extruded aluminum frame shall be gasketed and secured to the housing by four (4) captive screws. An internal stainless steel wire leader shall be tethered to the frame to facilitate relamping. The frame shall be white (standard).

REFLECTOR: Shall be highly polished, multi-faceted, prefocused anodized aluminum.

MOUNTING YOKE ASSEMBLY: Shall consist of a 12 gauge C.R.S. yoke with a wiring compartment and an integral 5" O.D. x 1/2" deep spun steel canopy. The die formed wireway cover is secured to the yoke by two countersunk fasteners. The assembly mounts directly over a 4" octagon box. Standard color is white.

REMOTE BALLAST : For lamp wattages from 70-175W, shall be encased and potted, HPS, CWA with a B sound rating. For lamp wattages from 250-400W, shall be encased and potted, HPF, CWA with a C sound rating. All ballasts are provided with an integral wire splice box.

PRODUCT LISTING: Shall be U.L. and C.S.A. listed for Damp Location.

PATENT PENDING: The housing contours of the luminaire constitute a trademark of Forum, Inc.

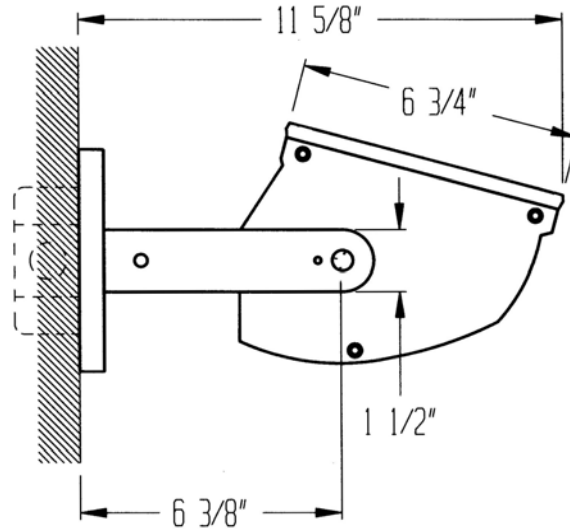

Quasar/ Projector Series	Remote Ballast Wall Mount	Finish WH=White CC=Custom
QUA	1WM	
Listing W=Wet Blank=Damp	Indicates Wattage 70MH 175PS 100MH 250PS 175MH 320PS 250MH 350PS 400MH 400PS *70WMH TD-6 *150WMH TD-7 * N/A with Fusing and Quartz Restrike	Options DS=Deflector Shield CBB=Cross Blade Baffle RBT=Remote Ballast Tray EM-Q=Quartz Restrike EM-S=Quartz Socket WL=With Lamp F=Fusing

CANDLEPOWER SUMMARY

CATALOG NO: QUA-175MH-1-WM
LAMP TYPE: M175/C/U/MED
LUMENS: 10750
FIXTURE EFFICIENCY: 66.6
LUMINAIRE WATTS: 205
TEST REPORT NO: 9642.0

ANGLE	CANDELA
180	2243
175	2682
165	3303
155	3250
145	2881
135	2455
125	2044
115	1461
105	843
95	431
90	269
85	128
75	0
65	0
55	0
45	0
35	0
25	0
15	0
5	0
0	0

