

FORUM

QUASAR/PROJECTOR

CEILING/WALL MOUNT

JOB _____

TYPE _____

FORUM QUASAR/PROJECTOR SERIES

The **QUASAR/PROJECTOR** is a heavy duty luminaire with a high degree of beam control. The optics are designed to evenly illuminate either vertical or horizontal surfaces.

APPLICATIONS: Classrooms, Office Areas, Libraries, Lobbies, Retail Stores, Atriums.

MOUNTING: The **QUASAR/PROJECTOR** can be mounted to illuminate vertical or horizontal surfaces.

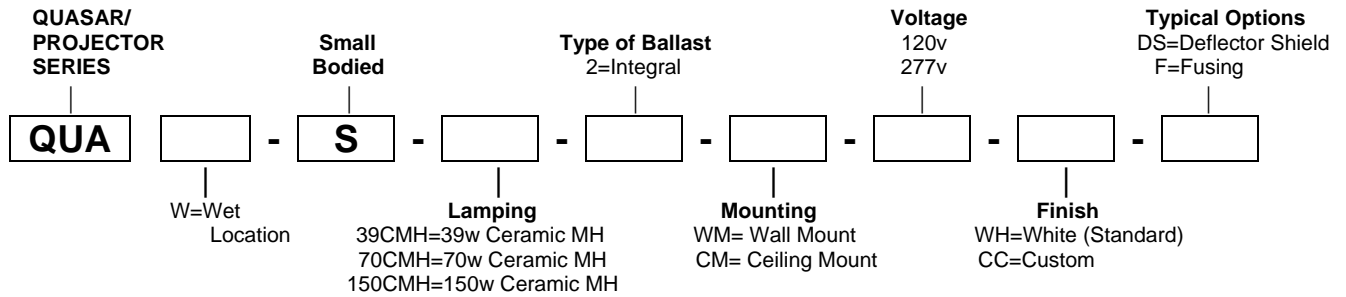
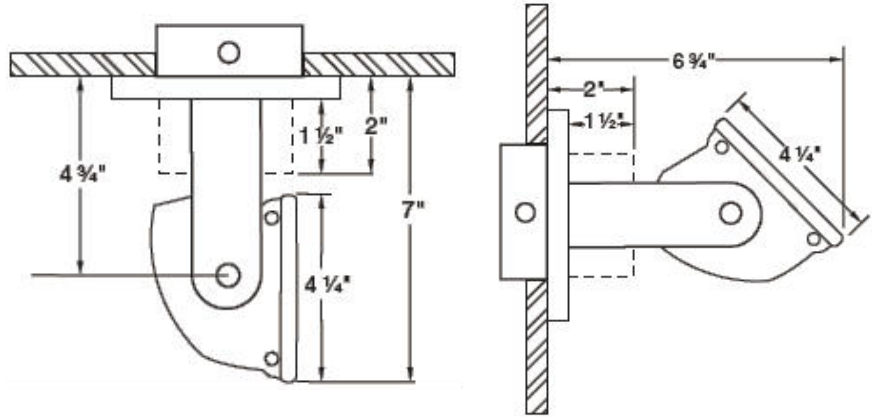

SPECIFICATION:

HOUSING: Shall be .125" thick extruded 6063-T5 aluminum with external surface ribbing for improved heat dissipation which will prolong lamp life. The standard finish for the housing is white. The end plates shall be .375" thick aluminum, gasketed. The ends shall be painted white (standard). Custom finishes and bright dip anodized finish available. Consult factory.

LENS ASSEMBLY: Snap on acrylic lens standard.

REFLECTOR: Shall be highly polished, multi-faceted prefocused anodized aluminum, with symmetrical or asymmetrical distribution available.

PRODUCT LISTING: Shall be U.L. and C.S.A. listed for damp location. Wet Location optional.

PATENT PENDING: The housing contours of the luminaire constitute a trademark of Forum, Inc.