

FORUM

QUASAR/PROJECTOR

SEMI-RECESSED WALL MOUNT

JOB _____

TYPE _____

FORUM QUASAR/PROJECTOR SERIES

The **QUASAR/PROJECTOR** is a heavy duty luminaire with a high degree of beam control. The optics are designed to evenly illuminate either vertical or horizontal surfaces.

APPLICATIONS: Classrooms, Office Areas, Libraries, Lobbies, Retail Stores, Atriums.

MOUNTING: The **QUASAR/PROJECTOR** can be mounted to illuminate vertical or horizontal surfaces.

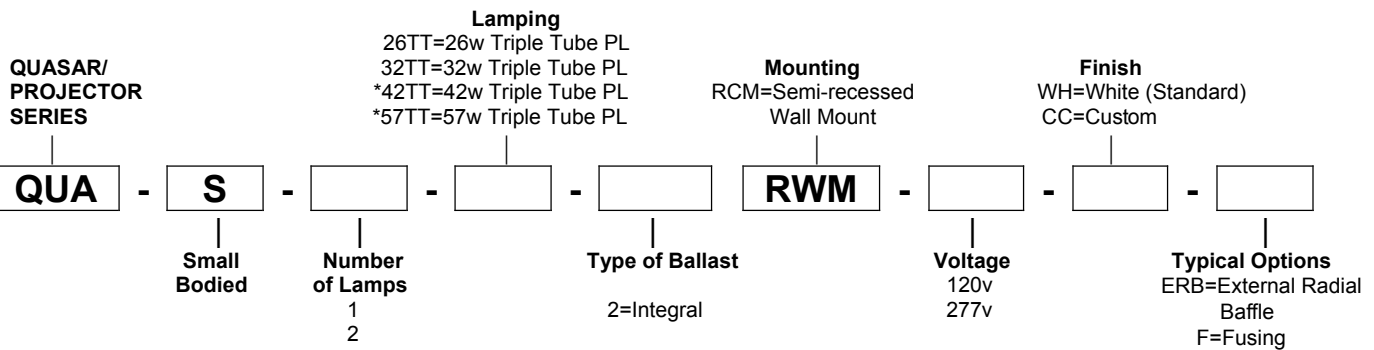
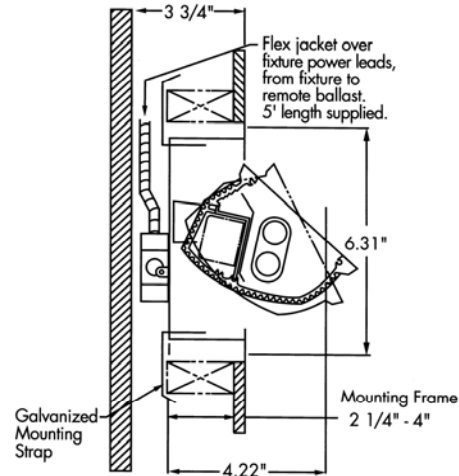

* Not available with lens

SPECIFICATION:

HOUSING: Shall be .125" thick extruded 6063-T5 aluminum with external surface ribbing for improved heat dissipation which will prolong lamp life. The standard finish for the housing is white. The end plates shall be .375" thick aluminum, gasketed. The ends shall be painted white (standard). Custom finishes and bright dip anodized finish available. Consult factory.

LENS ASSEMBLY: Snap on acrylic lens standard. Not available with 42W and 57W lamping.

REFLECTOR: Shall be highly polished, multi-faceted prefocused anodized aluminum, with symmetrical or asymmetrical distribution available.

PRODUCT LISTING: Shall be U.L. and listed for damp location.

PATENT PENDING: The housing contours of the luminaire constitute a trademark of Forum, Inc.